



# Anchoring study

Recommendations for the good usage of anchors in the Humanitarian Shelter sector

[www.ifrc.org](http://www.ifrc.org)  
Saving lives, changing minds.

 International Federation  
of Red Cross and Red Crescent Societies

**Shelter Research Unit**  
Innovating shelter

**Disclaimer:**

The information and research results displayed in this publication are indicative and intended to serve as mere guidelines for the good usage of anchors in the Humanitarian Shelter sector. The International Federation of the Red Cross and Red Crescent societies – Shelter Research Unit is in no way responsible for any errors or omissions that may arise from the use of this study.

Users of this study assume all risks and responsibilities. The International Federation of the Red Cross and Red Crescent societies – Shelter Research Unit will not assume any liability for damages, loss or claims, of any nature, including the death or injury of persons or property damage, associated with the use of or reliance upon information contained in this study.

**© International Federation of Red Cross and Red Crescent Societies, Geneva, 2018**

Copies of all or part of this study may be made for noncommercial use, providing the source is acknowledged. The IFRC would appreciate receiving details of its use. Requests for commercial reproduction should be directed to the IFRC at [secretariat@ifrc.org](mailto:secretariat@ifrc.org).

The opinions and recommendations expressed in this study do not necessarily represent the official policy of the IFRC or of individual National Red Cross or Red Crescent Societies. The designations and maps used do not imply the expression of any opinion on the part of the International Federation or National Societies concerning the legal status of a territory or of its authorities. All photos used in this study are copyright of the IFRC unless otherwise indicated.

Cover photo: Pablo Ruben/IFRC-SRU Bertrange – Luxembourg

**IFRC- SRU**

Headquarters  
Cité Henri Dunant 10, L-8095  
Bertrange, Luxembourg  
Telephone: +352 27 55 – 8902  
E-mail: [ifrc-sru@croix-rouge.lu](mailto:ifrc-sru@croix-rouge.lu)

P.O. Box 303  
CH-1211 Geneva 19  
Switzerland  
Telephone: +41 22 730 4222  
Telefax: +41 22 730 4200  
E-mail: [secretariat@ifrc.org](mailto:secretariat@ifrc.org)  
Web site: [www.ifrc.org](http://www.ifrc.org)

**02/2018****Follow us on:**

# **Anchoring study**

## Recommendations for the good usage of anchors in the Humanitarian Shelter sector

The International Federation of Red Cross and Red Crescent Societies (IFRC) is the world's largest volunteer-based humanitarian network. With our 190 member National Red Cross and Red Crescent Societies worldwide, we are in every community reaching 160.7 million people annually through long-term services and development programmes, as well as 110 million people through disaster response and early recovery programmes. We act before, during and after disasters and health emergencies to meet the needs and improve the lives of vulnerable people. We do so with impartiality as to nationality, race, gender, religious beliefs, class and political opinions.

Guided by *Strategy 2020* – our collective plan of action to tackle the major humanitarian and development challenges of this decade – we are committed to saving lives and changing minds.

Our strength lies in our volunteer network, our community-based expertise and our independence and neutrality. We work to improve humanitarian standards, as partners in development, and in response to disasters. We persuade decision-makers to act at all times in the interests of vulnerable people. The result: we enable healthy and safe communities, reduce vulnerabilities, strengthen resilience and foster a culture of peace around the world.



# Acknowledgements

This booklet is an attempt to consolidate technical information on anchoring solutions with the overall objective of contributing to the reduction of shelter-related vulnerabilities that put the inhabitants' lives at risks.

Anchors are commonly used in humanitarian response to fix and attach light shelters to the ground. In this publication anchors have been examined according to different parameters, such as resistance depending of the type of soils, cost effectiveness, ease and speed of set-up/dismantling/re-use when the shelter solution has to be mobile.

This study and in particular the test analysis on 18 anchoring solutions aims at providing field practitioners and decision makers with technical information and recommendations allowing them to identify the best anchoring option for their context of intervention.

The anchor test project that provided the data included in part II. of this Study was managed by Daniel Ledesma (IFRC-SRU Research Officer) and the volunteer Christoph Maiers, with support of the IFRC-SRU team.

The study itself was compiled by the volunteer Pablo Ruben and Daniel Ledesma. Major contributions were provided by Javier Vila Ferrero and Vincent Virgo (IFRC-SRU Research Officer).

External contributions were made by Professor Jospe Ignasi de Llorens Duran (UPC-Barcelona, Spain) and Alejandro Ledesma Nicrosi.

This project was funded by FVEMT (Fondation Veuve Emil Metz-Tesch), ALIAI (Association da Vinci), KUHN Constructions and ENECO (Ingénieurs et Conseil).

This document was published online on the website of the IFRC-SRU ([www.ifrc-sru.org](http://www.ifrc-sru.org)). © January 2018

Any commercial usage of this document or parts of it is strictly prohibited. This document might be reproduced and spread, partially or entirely, as long as the original author is mentioned. Also, sending a copy (digital or physical) to the original author is highly appreciated.

# Table of contents

<b>I.</b>	<b>Background knowledge</b>	<b>9</b>
<hr/>		
<b>I.A</b>	<b>Glossary and overview</b>	<b>9</b>
<b>I.B</b>	<b>Above the ground</b>	<b>11</b>
I.B.1	Environment-related conditions	11
I.B.2	Shelter-related conditions	12
<b>I.C</b>	<b>Anchors: transferring forces to the ground</b>	<b>13</b>
I.C.1	Pegs	13
I.C.2	Screws	13
I.C.3	Percussion-driven	13
<b>I.D</b>	<b>Under the ground</b>	<b>14</b>
I.D.1	Force transfer to the ground	14
I.D.2	Influence of soil	15
I.D.3	Challenges and risks	16
<b>II.</b>	<b>Test results</b>	<b>18</b>
<hr/>		
<b>II.A</b>	<b>Methodology</b>	<b>18</b>
<b>II.B</b>	<b>Preliminary test</b>	<b>19</b>
II.B.1	Pegs: Depth is better than inclination!	19
II.B.2	The same goes for screws	19
II.B.3	V- and T- angles should point to the tent!	20
<b>II.C</b>	<b>General test results</b>	<b>21</b>
II.C.1	Weather exists under the ground too	21
II.C.2	Maximum performances with and without a displacement limit	22
<b>II.D</b>	<b>Specific and comparative test results</b>	<b>23</b>
II.D.1	Test data	23
II.D.2	Performance analysis (quantitative)	23
II.D.3	Practical concerns (qualitative)	25
<b>II.E</b>	<b>Further analysis</b>	<b>26</b>
II.E.1	Don't trust the price tag!	26
II.E.2	Depth increases performance, independently of the type	27
II.E.3	X-crossings: a limited improvement	27
II.E.4	Combine pegs!	27
II.E.5	Combine percussion-driven anchors!	28
<b>II.F</b>	<b>Conclusions</b>	<b>28</b>
<b>II.G</b>	<b>Alternatives</b>	<b>29</b>

**III. Recommendations for application 32**

---

<b>III.A Triple AAA: Alternatives, Accessible, Aware</b>	<b>32</b>
<b>III.B Basic recommendations for safe usage</b>	<b>33</b>
<b>III.C Handout</b>	<b>35</b>
<b>III.D Tested anchor specifications</b>	<b>37</b>





Anchors and foundations more generally play an essential role in the structure of shelters. A failure of the anchors can be the first in a series of dramatic ones. Therefore, it is essential to perceive anchors as an integrated part of a building rather than as a separated object.

Two possible consequences of anchor failure exist:

- The shelter being blown away by the wind as ground resistance is lost
- The shelter collapsing due to loss of structural stability

Weight of the standard family tent (2009)

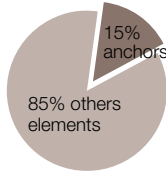

Anchors are relevant in the humanitarian sector for mainly two reasons. First, good anchoring is a prerequisite to reach the effective shelter lifetime. Second, it is relevant to economic and effective material usage: within the standard family tent (2009 model) it accounts for as much as 15% of the total mass (incl. hammer).



This anchoring study includes a detachable handout with recommendations for field purposes. While the first one provides an extensive study of anchor usage considerations, the latter one offers a short overview of the most important findings.

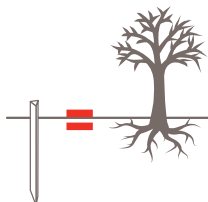

The anchoring study is subdivided in three parts discussing the question ‘what are the major aspects to consider using anchors in the humanitarian sector?’.

The first part focuses on the background knowledge. After introducing the most important terms in a glossary, the influences will be discussed from three perspectives, similarly to a tree: first, the parameters above the ground, second the impact of the type of anchor itself, and finally the parameters under the ground.

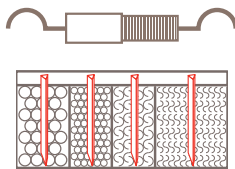

A second part illustrates these variations by introducing results of the testing of 18 anchors. Fundamental aspects such as the positioning of v-pegs will be discussed before looking at the relative performances of the different pegs. Further questions such as the influence of price, length or the potential of combinations will also be treated. Finally, the role of alternatives will be discussed and illustrated by example approaches.



The third and final part gives practice recommendations in three steps. First, a good anchoring practice will be defined by three As, similarly to bond credit rating. Those three As are present all along the study. Furthermore, guides such as step by step checklists or the handout will be provided for field practice. The annex contains the specifications of the tested anchors



## I.

## Background knowledge

## I.A Glossary and overview

'**Anchors** are foundations for tensile forces, to resist generally uplift.'

'**Active anchors** are prestressed by initially tensioning against a steel bearing plate. The level of prestress is a percentage of the design-working load. When the prestressed anchor is externally loaded, it behaves as a much stiffer member than a dead anchor.'

'**Passive anchors**': only act against the soil when loaded. They move more than active anchors, but they are simpler and involve fewer problems of relaxation and durability. They can be divided into two main groups according to whether they reach the surface of the ground or are buried.'

### 1. Anchors reaching surface:

These are mostly **pegs**, also called stakes: various profiles include round, flat, V-shaped or T-shaped. Most common materials are metal, plastic and wood. Force is essentially transferred by compressing the soil.

Another type of anchor that can reach the surface or be buried is the **ballast** anchor. They are generally made of a heavy material such as concrete, earth or water. This one uses its own weight to create friction which is resisting forces applied to it. If the ballast anchor is buried, the friction surface is bigger and the anchor is stronger.

### 2. Buried anchors:

On top of the buried ballast anchors, two other types of anchors are also buried:

The **screw anchor** (or helical anchors) consists of a rod with a helix straddling or in some cases of a body in the form of a helix itself. They are inserted into the soil just as a screw and use the surfaces of the helix in order to create resistance by compression of the soil above.

The **percussion-driven anchor** (or mechanical anchors) are composed of a base attached to a cable called tendon. Similarly to screw anchors, they use the surface of the buried and armed base to create resistance by compression.





A **beneficiary** is 'a person or group that receives benefits, profits, or advantages.' In this publication, the term beneficiary will thus be used to designate the person or group of person which is inhabiting the shelter secured by the anchors.

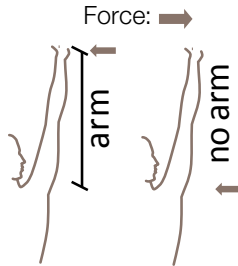

A **force** is the 'strength or power exerted upon an object; physical coercion; violence:'. It is usually represented by one or several arrows.

A **force moment** is the measure of a force's tendency to cause a body to rotate around a given point. It appears when there is a moment arm, the perpendicular distance between the moment point and the force axis. It is calculated with the following formula:

**Moment = Force x Distance**



For an object which is immobile, the sum of moments in a given point is always equal to 0.

An **installing person** is a person which installs the anchors (it can be the same as the beneficiary but does not need to). Install is defined as 'to place in position or connect for service or use' in Thesaurus. The installing person is thus the one which inserts the anchor into the soil, making him ready to use.



**Local and spatial memory** is the ability of local communities to acquire and save knowledge about their own life environment. Recurrent phenomenon's including storms, floods and droughts but also specific events such as pollution or building activities are well known to local inhabitants. As this precious information is often remembered in local language or even oral traditions only, a participative approach can be beneficial.

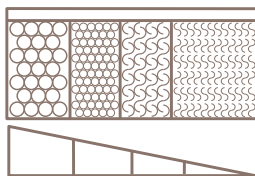

'**Soil** is a mixture of minerals, organic matter, gases, liquids, and countless organisms that together support life on Earth. Soil is a natural body called the pedosphere which has four important functions: it is a medium for plant growth; it is a means of water storage, supply and purification; it is a modifier of Earth's atmosphere; it is a habitat for organisms; all of which, in turn, modify the soil.'

Wind Speed = 2D



**Wind speed** is a flow velocity caused by air moving, usually from high pressure to low pressure and due to changes of temperature. It can be measured instrumentally (with an anemometer) or by perception (using the Beaufort scale).

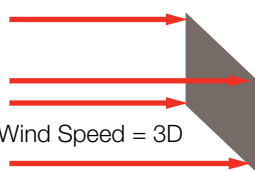

**Wind pressure** is a property resulting from wind speed. It is generally expressed with the letter q and defined by  $q = \frac{1}{2} \rho v^2 \omega$ .

$\rho$  being the density property of the air,  $v$  being the wind speed and  $\omega$  a shape coefficient. Negative pressure exists and is often referred to as **suction**.

## I.B Above the ground

Any shelter is surrounded by air and thus impacted by weather conditions among which wind, snow and rain. In order to avoid the shelter moving, this one needs to be attached to the ground by mean of anchors. Incident forces are directly impacting anchors: they are the ones pulling on the anchor and need to be transferred to the ground. Incident forces depend on several parameters which can be divided in two parts: environment and shelter-related conditions.

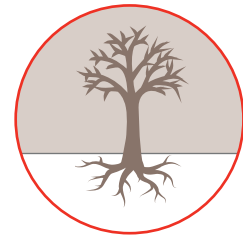

### I.B.1 Environment-related conditions

- The regional climate: precipitations, snow and wind forces, including seasonal variations.
- The exact location of the shelter including the direct context: trees, hills, etc.
- Risk-management decisions: the wind speed chosen as a reference to design the shelter. Reference wind speeds should always be chosen to stay on the safe side, and are often much higher than the average wind speeds.
- When considering wind forces, one needs to be careful. In fact, those ones are often expressed as a speed (such as in the beaufort scale below) while the more important parameter are the wind forces, among which the wind pressure which is proportional to the square of the speed (definition on p.8), thus:



Design wind speed

**wind speed ≠ wind pressure**

**A given increase in wind speed has always a bigger effect on the wind forces impacting shelter!**

Relative pressure\*  
(no unit)

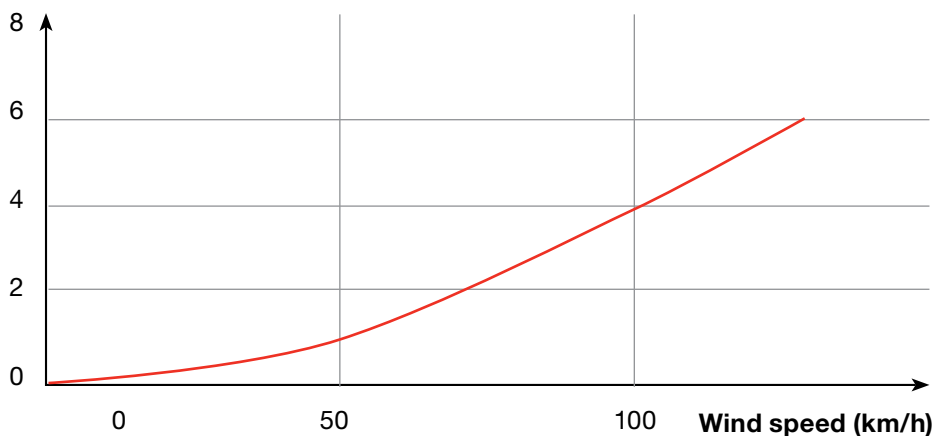

\* For the relative pressure, a value of 1 (no unit) was taken as a reference for 50 km/h.  
All values are based on the assumption that the wind speed is the only variable changing.

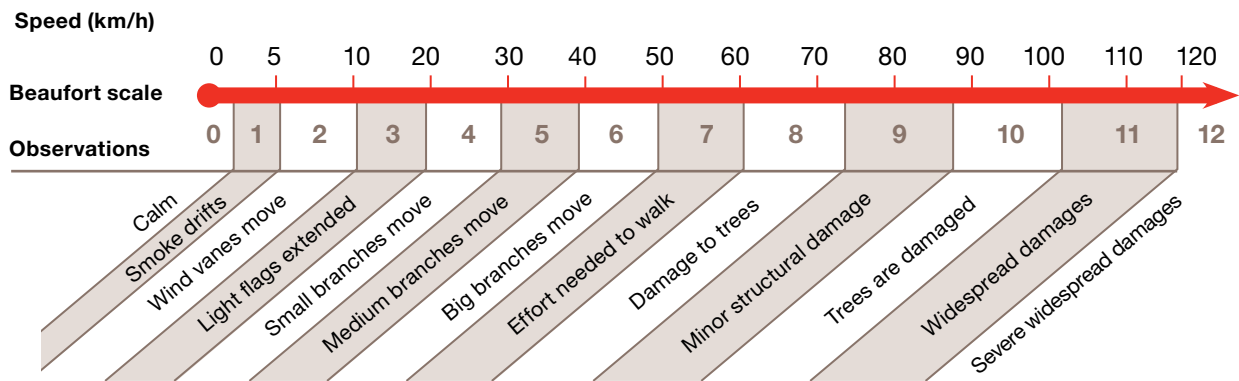

### I.B.2 Shelter-related conditions

The quantity of forces absorbed by the shelter depends on:

- Technical specifications of the shelter, including:

Size	
Shape and volume	
Mass (can increase with snow and rain)	
Number of guy ropes/anchoring points	

- The environmental conditions which depend on two intertwined aspects:

Orientation	
Exposure	



- Don't take any risks if shelters cannot be strengthened – the consequences of dismounting for a few days are much smaller than the ones of unusable or blown away shelters!
- Forces applying to the shelter are highly dependent on the exact situation and shelter.
- Wind speed is different from wind pressure, one of the forces impacting buildings.
- Even after completion, weather conditions need to be monitored. If those ones become higher than the one structures are designed for, measures need to be taken: see part II.C.1 and part II.D.3



## I.C Anchors: transferring forces to the ground

The aim of this part is to give a short introduction to the state of the art of the most common types of anchors for the humanitarian (these are also the types of anchors tested in part II). For logistic and practical reasons, mainly passive and lightweight anchors transferring forces to the soil will be studied, in opposition to ballast anchors which rely on their own mass.

Among the passive lightweight anchors, three categories with differences in shape, usage and force transfer methods were identified. These ones will be discussed here and test performances can be found in part II.C.

### I.C.1 Pegs

A profile made of wood or metal which is pushed into the ground. Profiles include round, V-shaped or T-shaped ones. While steel and aluminum are the most common materials, plastic can also be found.

**Extra material needed:** a hammer

**Procedure:**

- position the peg in the good inclination angle (see part II.B.1) and orientation (see part II.B.3)
- hammer the peg into the soil until only the attach end sticks out (leave 1 cm under it to attach the rope)
- Attach the guy rope to the attach end

### I.C.2 Screws

Similarly, to a peg, it has a pointed stake with either a helix straddling or the whole main body has the shape of a screw.

**Extra material needed:** a steel or a wooden bar

**Procedure:**

- Position the anchor perpendicularly to the soil (See part II.B.2)
- Place a metal rod half-way through the eye-hole and rotate it in the sense of the helix. Stop drilling when only the eye-hole is above the ground.
- Attach the rope to the anchor and tension it.
- When installing screw anchors, be aware that the whole anchor will move in the axis of the pulling force. A diagonal guy rope combined with a vertical stick-rod or vice-versa will result in a danger by loosening the guy rope.

### I.C.3 Percussion-driven

A metal plate which is attached to a tendon. The guy rope in itself is attached to the other end of the tendon. Correct positioning is particularly important as it might be impossible to remove the anchor once installed.

**Extra material needed:** a steel bar and a hammer (suppliers often offer specially designed tools too)

**Procedure:**

- Position the base with the sharp end facing the soil
- Insert the metal driving rod into the round hole on the other side of the base. Hammer onto the driving rod while keeping the tendon straight.
- Once only the eye-hole remains above the surface, remove the metal driving rod.
- Pull on the cable (for instance by inserting the driving rod into the eye-hole)

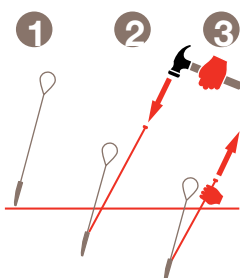
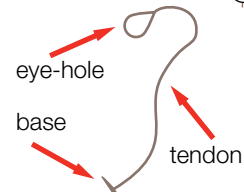
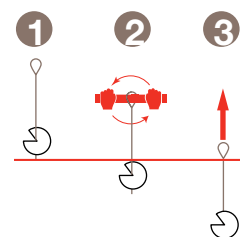
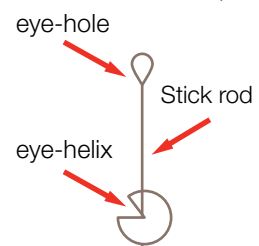
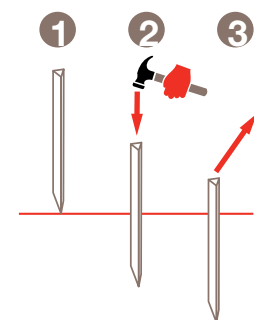
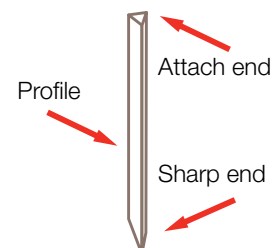
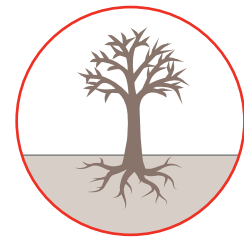

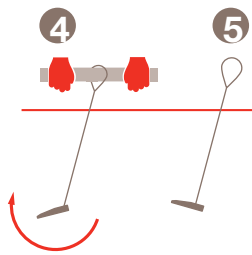

- Once the base is deployed, the anchor is armed (this cannot be checked visually), the resistance increases and the guy rope can be attached on the eye-hole.

When installing percussion-driven anchors, be aware that the tendon will move in the axis of the pulling force. A diagonal guy rope combined with a vertical tendon or vice-versa will result in a danger by loosening the guy rope.



- The differences between the types of anchors are fairly big and need to be taken into account.
- Instructions about how to use the anchors should always be distributed with the products
- If percussion-driven anchors are chosen, special attention should be paid to the arming process.
- If the force is pulling in a different direction than the axis of resistance, the anchor might loosen the guy rope by moving. This is a risk to be considered beforehand.

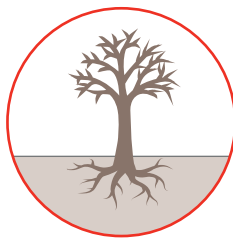

## I.D Under the ground

### I.D.1 Force transfer to the ground

The main way lightweight surface anchors transfer forces to the ground is by **compression**. Failure of this type of resistance is generally indicated by soil bulging up in the compression zone, above the surface. This phenomenon explains why the anchoring depth counts: as a deeper/longer anchor can activate more soil, its resistance is bigger.

**Friction** is another type of force used by anchors to transfer forces. This is for instance how pegs acquire resistance along their own axis. As a guy rope is composed by a horizontal and a vertical component, this aspect is just as important. Failure of friction is generally indicated by pegs jumping out of the ground without any significant damage to the surrounding earth. This phenomenon explains why a peg with a bigger diameter has a bigger holding power: when the peg is inserted, more soil needs to be displaced, resulting in stronger compaction. Finally, friction increases as more and/or denser soil is in contact with the peg.

Percussion-driven and screw anchors too use both friction and compression. However, it is hard to dissociate both as they are oriented in the same axis.

Pegs which slide out of the soil lose a considerable amount of resistance as both friction and compression are reduced. On top of that, the moment created by the force on the guy rope is bigger as the distance with the soil (resistance) increases. Therefore, anchors which slid out of the soil should be moved by the length of the anchor and installed correctly making a new hole again.

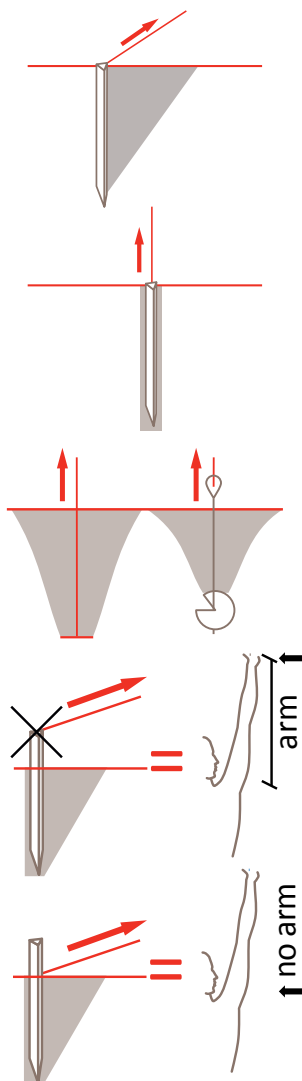

This difference in force moments also explains why it is important to always fully insert the anchor into the soil. In the case this is not possible (e.g. too hard soil), the rope should always be attached close to the ground. Otherwise, an unnecessary force moment appears and weakens the anchor.



- Pegs use compression to transfer horizontal forces and friction to transfer vertical ones.
- Screws and percussion driven anchors use both friction and compression in the same axis.
- Always attach the rope as close as possible to the ground as this reduces the force applying to the anchor.
- An anchor which is difficult to insert into the ground indicates a ground which is more difficult to compact and finally, a bigger resistance.
- Anchors which do not reach their intended implementation depth are considerably weaker.
- Regularly check anchors after installation and correct them if necessary. In the case an anchor cannot be fully inserted, always attach the rope at the bottom, close to the soil.



Gravel/Rock &gt; 2 mm



Sand &gt; 0,05 mm

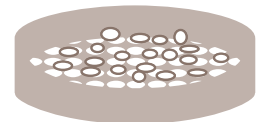

Silt &gt; 0,002 mm

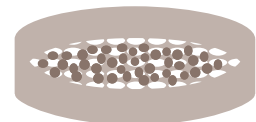

Clay



illustrative drawing, not a real test for identification

## I.D.2 Influence of soil

Depending on the type of soil, the amount of force that can be transferred by a single anchor can be different. Depending on their properties and more particularly the texture, soils behave very differently. One of the most commonly used classifications for soil texture is the USDA taxonomy:

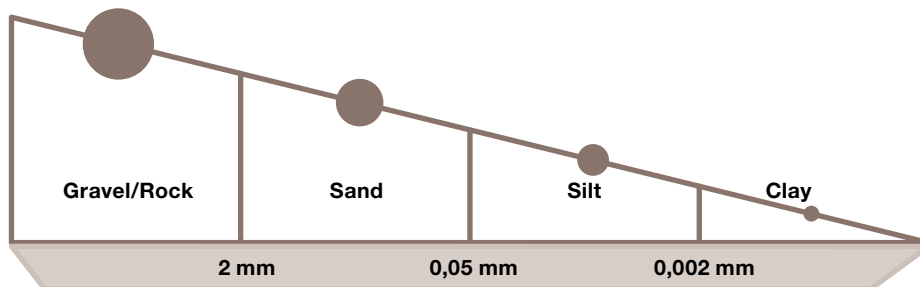

It divides the components of soil into four categories with different sizes: all particles bigger than 2 mm belong to 'gravel/rock' and all smaller than 0.002 mm belong to 'clay'. In between, two categories exist: 'sand' for 0.05 till 2 mm and 'silt' for 0.002 to 0.05mm.

As this approach is theoretical, soils of only one grain size are rather unlikely to be found. In fact, most soils consist of a mix of all with one or two major types. For instance, the term loam which is often used designates a mixture of the sand, silt and (often in a smaller amount) clay.

For identification of soil types, a short method is provided by the USDA. A more extensive explanation can be found in the publication *Suitability of Local Soil for Cost-Saving Construction Techniques*.



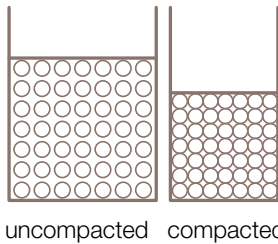

### I.D.3 Challenges and risks

It is possible to identify the mechanical properties directly by testing or indirectly by identifying the type of soil. However, even if such data is obtained, the validity is always limited as uncertainties persist. These ones are mainly related to variations resulting from punctual, cyclic or permanent external influences. For instance, non-compacted soil left by a building site might take as much as 30 years to reach a high density (comparable to natural soil).

The local spatial memory is particularly crucial to identify those ones. In fact, a lot of knowledge is treasured by local inhabitants (oral or written). This includes information such as recurrent floods, strong winds, local customs. For instance, any free parcel in dense urban settings probably has a reason (pollution, ownership, etc.) which can easily be identified by asking locals beforehand.



The importance of these aspects is even bigger in the context of natural disasters. As many natural phenomena are cyclic, past disasters are potential future disasters which can seriously affect soil characteristics (again).



In order to limit the impact of variations, those ones should be identified beforehand. This can be done by conducting several times the soil investigation at the **depth of implementation** of the anchors: dig several holes distributed over the entire parcel. This type of investigation should be conducted implicating the people who know most about the location, thus the local inhabitants.

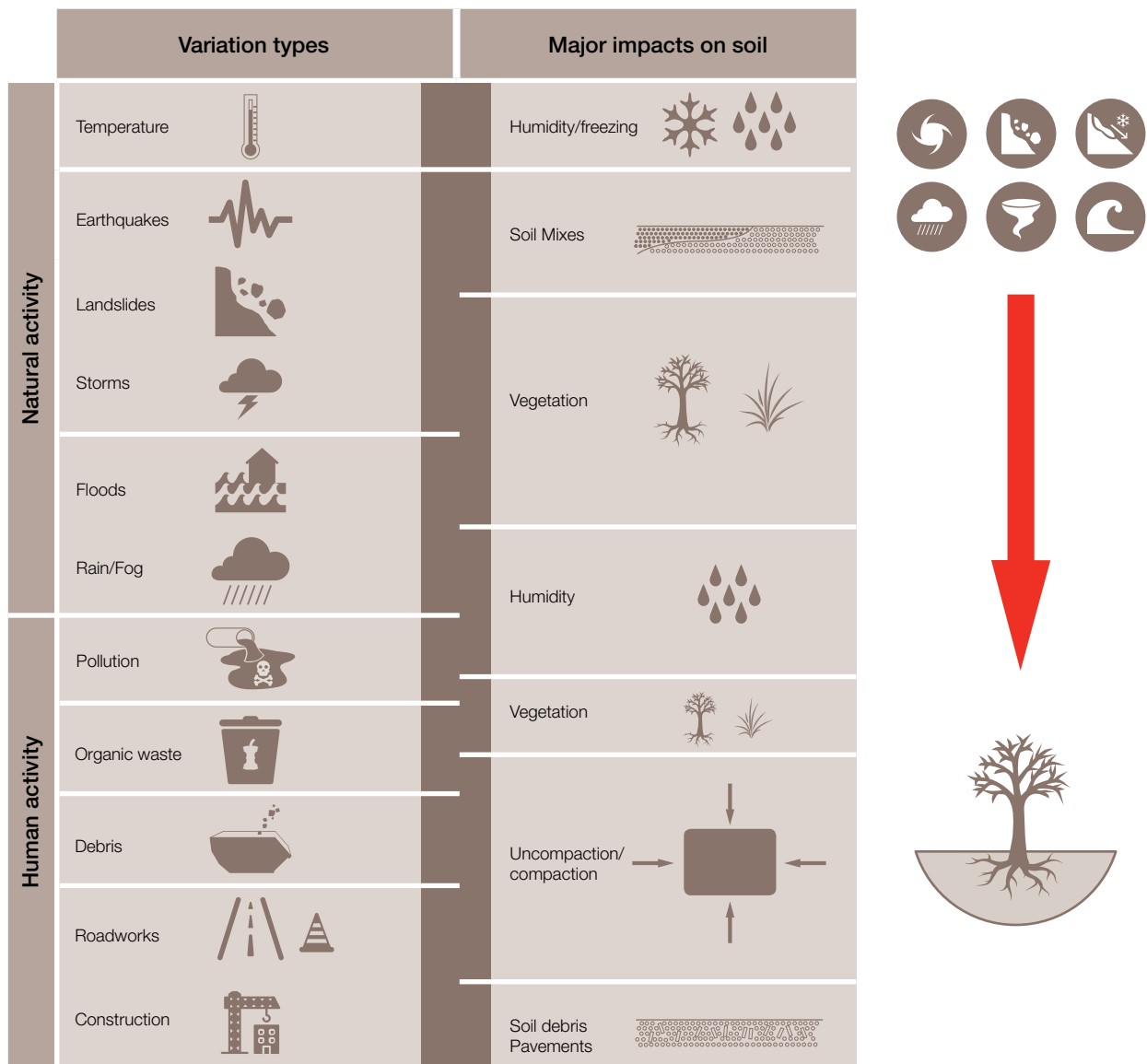

Once realized, the potential risks identified, for instance seasonal increases in humidity, need to be taken into account as their precise impact on the anchoring performances is hardly predictable. Moreover, caution is also necessary as unidentified risks might appear: whenever the context changes considerably, special attention should be given to anchors.



- As two types of soil are never 100% identical: different contexts = different soils = different anchor performances.
- Don't trust previous experiences when using pegs: a peg which worked in the same location a few years ago will not necessarily work in that location again.
- When identifying a location, cross-checking at different depths and at different points is necessary. A few meters are sufficient to change the type of soil.
- Even once identified, the performance of an anchor can change as it is impacted by external influences (i.e. humidity variations)



## II.

## Test results

## II.A Methodology



In order to obtain useful data inputs for the identification of important aspects, a series of test was conducted. The materials used include the following:

- A pulling system composed of a steel cable, a motorized winch and a triangular steel construction to control the angle of pull.
- Measuring system: dynamometer.
- Four soil trenches, dimensions  $l=18$ ,  $w=0.8$  and  $h=0.6$  to 1.5m were filled with different kinds of soils, compacted in layers of 30cm. These soils were chosen in order to create a representative diversity (sand, silt, rocky sand and clay rocky sand. A fifth sample was provided by the original natural soil (clay+sand)).
- Several different anchors belonging to three categories: 8 pegs, 3 screws and 7 percussion-driven ones (see annex for more details).

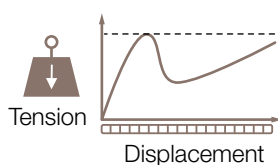
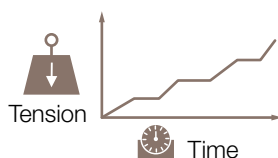

A total of 66 suppliers were contacted, 37 anchors were received, out of which 18 were finally selected for the final test sets. A detailed overview of the tested anchors can be found in the annex of this publication, part III.D.

Similarly, to wind loads applying punctually, the test was conducted by activating the winch step by step, hereby pulling each time a bit more on the anchor. Each time, the displacement and the forces were measured and written down. The obtained data resulted in two outputs: the maximum performance for a displacement lower or equal to 5 cm (+/- 1) and the absolute maximum performance measured independently from the displacement.

**Disclaimer:** Data published should be used carefully as it was obtained with specific soils, anchors and at specific moments. The study illustrates the diversity of the field and draws guidelines for practice. Therefore, no guarantee of the performances obtained is given.

## II.B Preliminary test

### II.B.1 Pegs: Depth is better than inclination!

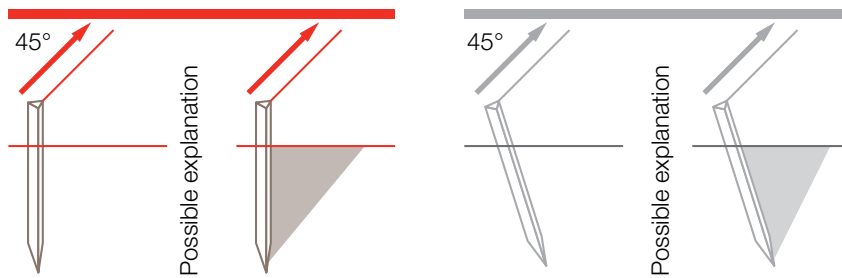

Measured performances in clay sand soil

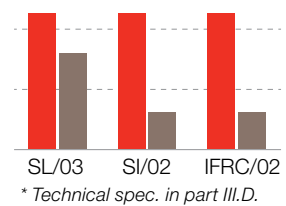

Tests clearly show that the effect of implementation depth is significant – this is also the case for pegs. Therefore, it is recommended to implement pegs vertically, except if the risk of being pulled out on the own axis is too big (=when the angle between rope and soil surface is smaller than 45°). Correct application can increase the performance by as much as 20%.

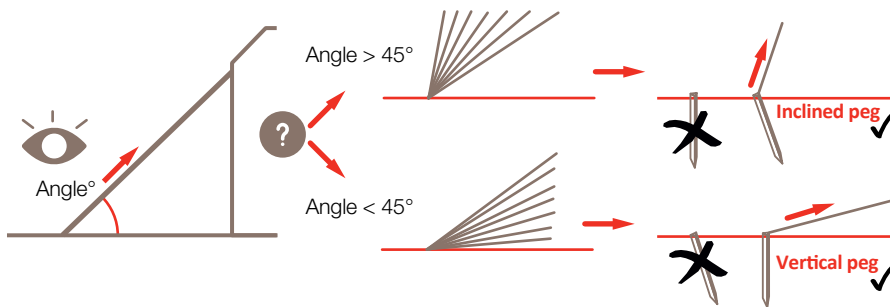

### II.B.2 The same goes for screws

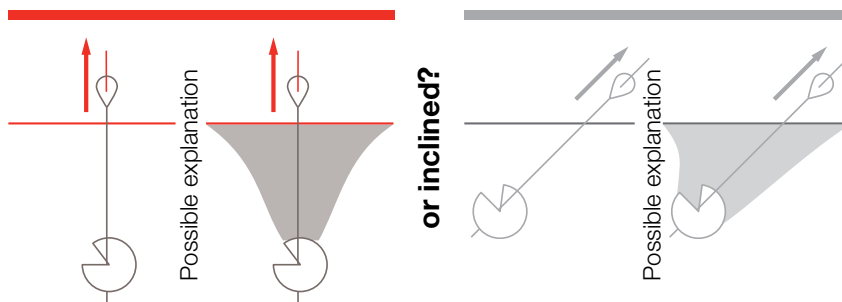

Inclined peg Vertical peg  
Angle <math>< 45^\circ</math> Angle <math>> 45^\circ</math> Angle <math>^\circ</math>

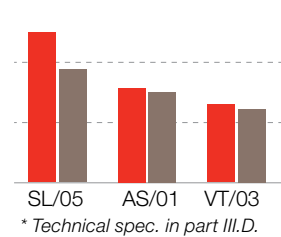

Tests showed that screw anchors are more efficient if used to resist against vertical rather than diagonal uplift.

An important consideration of both screw and percussion-driven anchors is that those anchors should be implemented in the axis of pulling.

### II.B.3 V- and T- angles should point to the tent!

Both possible positions were tested for V- profile pegs. Test results show that when implemented with the 'sharp side' pointing to the tent, performances are approximately 20% higher. A likely explanation is that most soil is involved on the side of the guy rope (indicated by soil bulging up on that side when the anchor fails). The phenomenon behind is very likely sides of the V involving more soil in that orientation.

Measured performances of V-pegs in clay sand soil

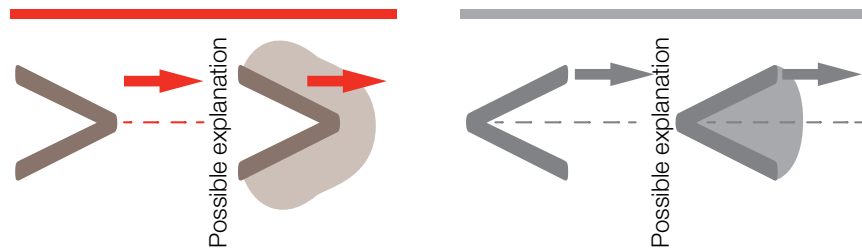
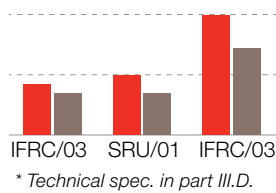

The same goes for T-pegs. The only T-peg model, IFRC/04 was tested in both positions. The outcome is very similar: the peg works best when implemented with the sharpest side pointing to the tent/guy rope. Performances are approximately 20% higher when this type of peg is used in the correct orientation. A similar phenomenon can be supposed here.

Measured performances T-pegs (IFRC/04)

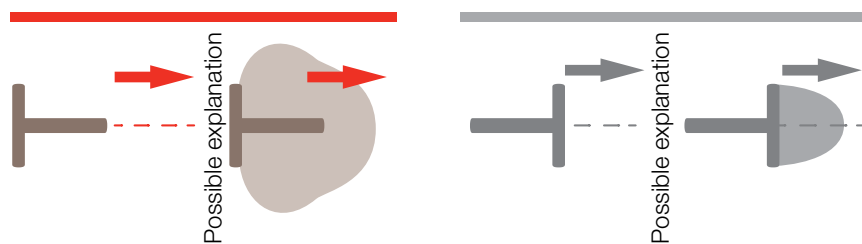
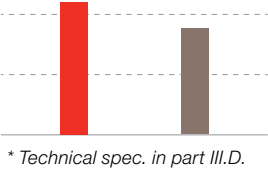

- Screw anchors are better suited for vertical than for diagonal pull.
- Pegs were observed working best when implemented vertically into the soil. However, a guy rope pulling in the axis of the peg should always be avoided. Therefore, if the angle between the guy rope and the soil is smaller than 45°, the angle should always be installed vertically. Correct installation increases the performance by approximately 20%.
- V- and T-profiles showed best performances when used with the sharp side pointing in the direction of the tent/guy rope. Correct usage increases the performance by approximately 20% - together with the correct inclination, approximately 45% more resistance can be obtained!

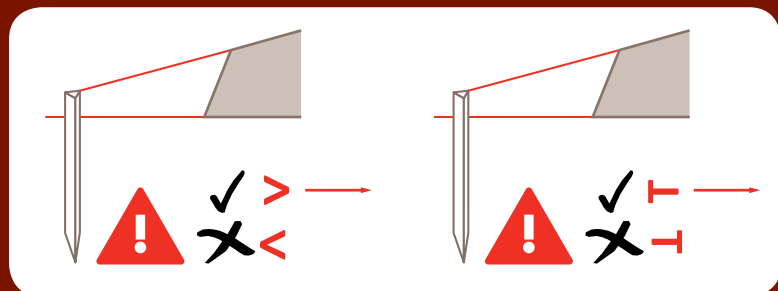

## II.C General test results

### II.C.1 Weather exists under the ground too

The influence of the context on the soil was discussed in part I.D.3. Test results clearly confirm this as from a day to another major variations were observed. Below, a table illustrating this with the different tests of the anchors IFRC/03 and IFRC/04 can be found.

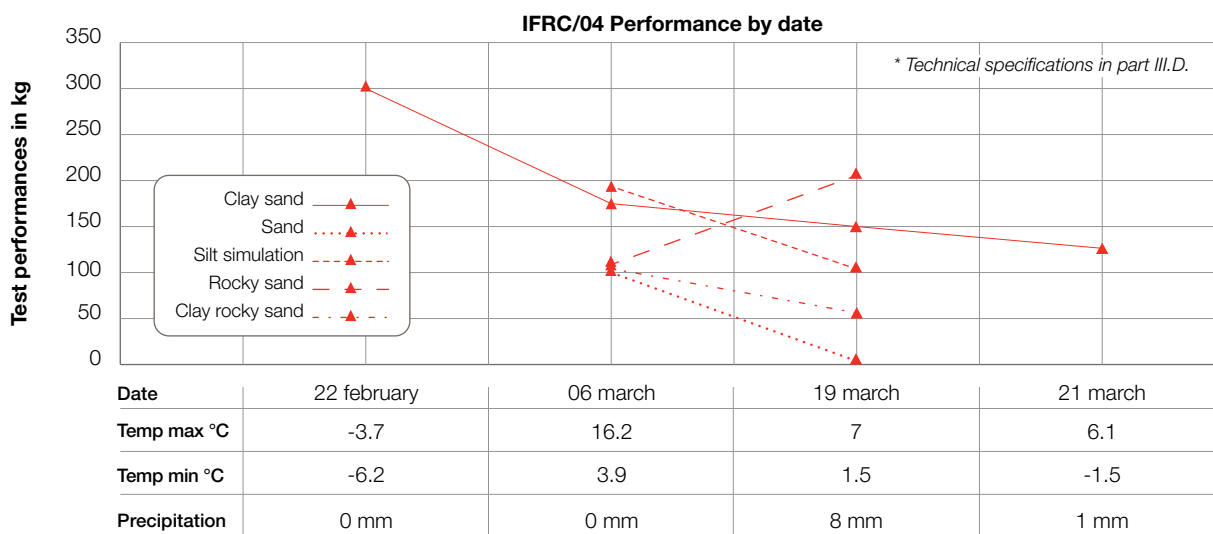

\* Weather data: [www.infoclimat.fr](http://www.infoclimat.fr)

Different performances have been measured depending on the day. Performances increased up to 100% in the period 06-19 march. The performance measured for clay sand soil on 22 February is more than 100% higher than the one measured on 21 march.

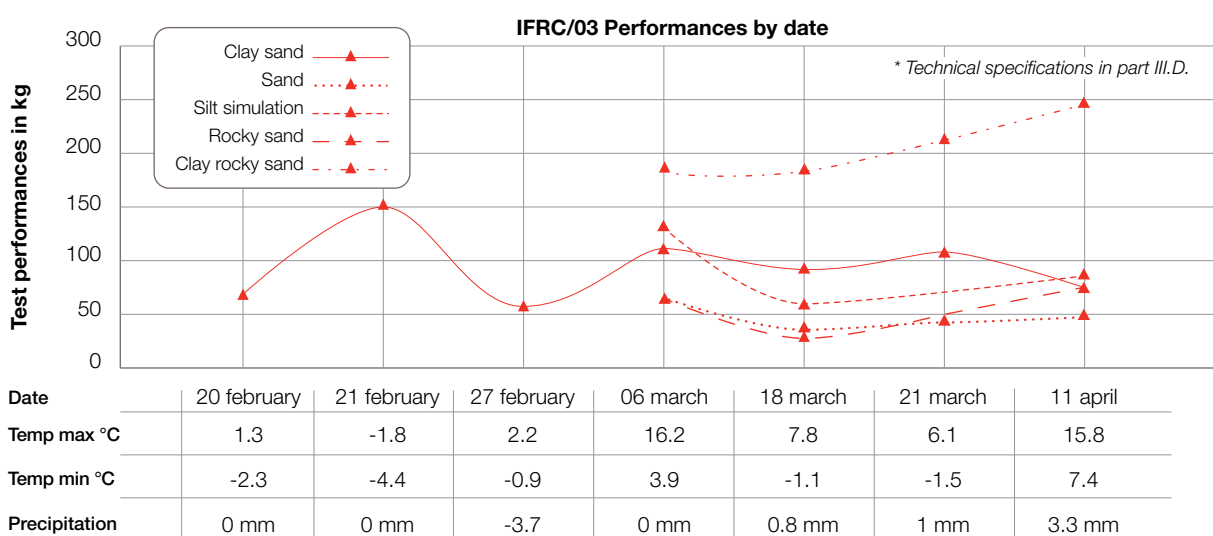

\* Weather data: [www.infoclimat.fr](http://www.infoclimat.fr)

For the IFRC/03 anchor too, different performances have been measured depending on the days. Performances changed more than 100% within a 6-day period (21 till 27 February 2013) and a 12 day period in march (06 till 18 march).

### II.C.2 Maximum performances with and without a displacement limit

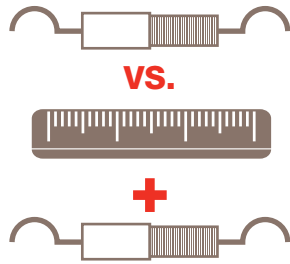

Two outputs were obtained with the tests: the overall peak performance without constraints and the peak performance reached with a constraint, a displacement limit of 5 cm (+/-1).

Big differences between the values, exceeding a ratio of 7.5, were sometimes observed. A specificity by type of anchors exists and can be observed in the graph below (this one is illustrative for the finding of all tested soil types): pegs and screws only show ratios smaller than '3' while the ones of percussion-driven anchors can reach as much as '8'. A resulting finding is that percussion-driven anchors can need substantially more displacement before reaching their maximum capacity.

A plausible hypothesis for this phenomenon is that the displacement of the anchor compacts the soil which is involved. Once the maximum soil density is reached, the performance is best and any additional displacement results in performance loss.

Independently of the explanation, this finding shows that special care must be taken while installing percussion-driven anchors. In fact, displacement might result in loosening the guy ropes and finally structural weaknesses.

**Ratios between the maximum resistance measured without and with a 5 cm displacement constraint**

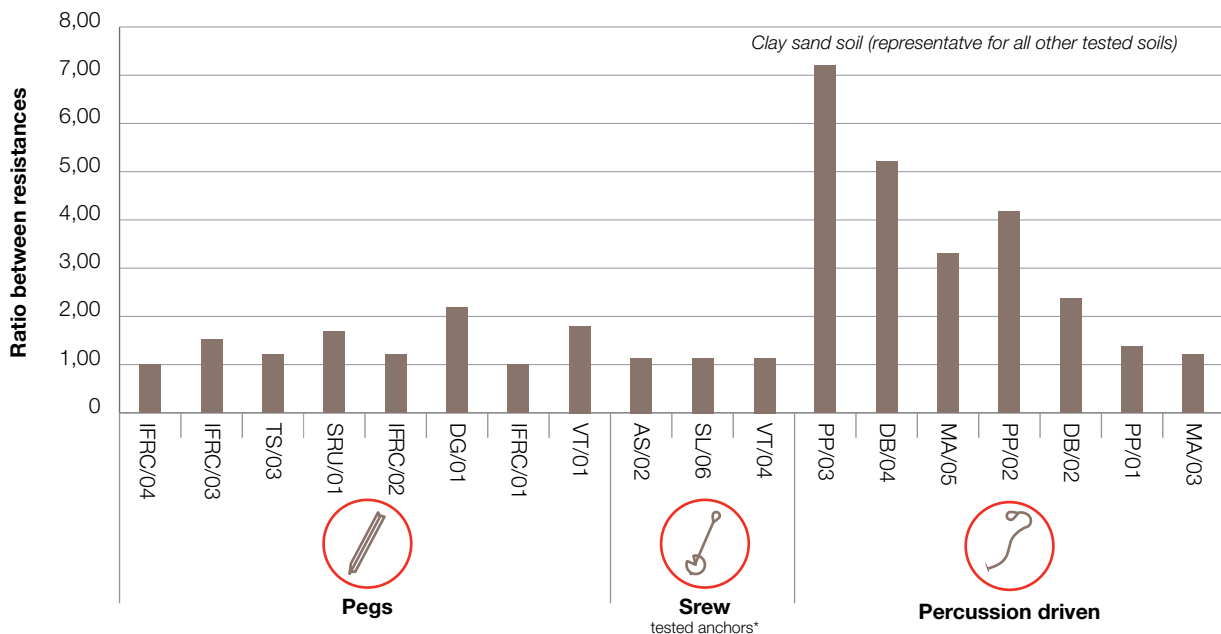

\* Technical specifications in part III.D.



- The climatic context has a major impact on the anchor performances. Depending on the day, the performances of an anchor in a given soil can be different.
- Depending on the type of anchors and soils, displacements bigger than 5 cm (+/- 1) might be required before reaching the full potential of the anchor (the maximum resistance). This is especially the case for percussion-driven anchors.





## II.D Specific and comparative test results

### II.D.1 Test data

The aim of the second part is to compare the different anchors tested. Following the initial findings, the tests were conducted by putting each anchor in its most favorable position. Among the outputs obtained, the maximum performance without any displacement constraint was chosen as it illustrates the potential of the anchors best. In case multiple data exists (for anchors tested in same soils on different days), the highest result was always chosen.

The results for the tests are shown in the graph on the next page. Each graph illustrates the situation for a specific type of soil. The scale contains relative number outputs (1=1200 kg) to facilitate easy comparison between graphs.

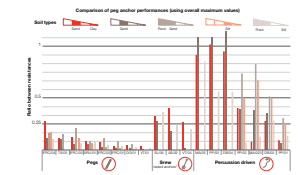

### II.D.2 Performance analysis (quantitative)

#### Maximal tension:

The highest resistances were observed for percussion-driven anchors. Independently of the soil, the strongest anchors always reach '0.5' (600kg) and in some cases the output was higher than '1' (1200 kg). For the case of screw anchors, forces measured were considerably lower: for all compatible soils, the most performing anchor reaches '0.25' in all of them. For pegs, only one model in one soil reaches the '0.25' threshold.

#### Compatibility:

The only type-wide incompatibility which was observed is the one of screw anchors in 'Gravel-Sand' and 'Silt'. Other incompatibilities were observed for the biggest percussion-driven anchors in 'silt' and 'rocky-sand' soil.

				*
Clay Sand	✓	✓	✓	✓
Sand	✓	✓	✓	✓
Silt	✓	✗	✓/✗	✓
Rock Sand	✓	✗	✓/✗	✓
Rock Sand Clay	✓	✓	✓	✓

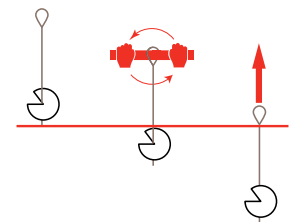

\*In opposition to the models tested, ballast anchors were not included in the test. However, their simplicity, compatibility and performance make it necessary to include them in the table.

**Comparison of peg anchor performances (using overall maximum values)**

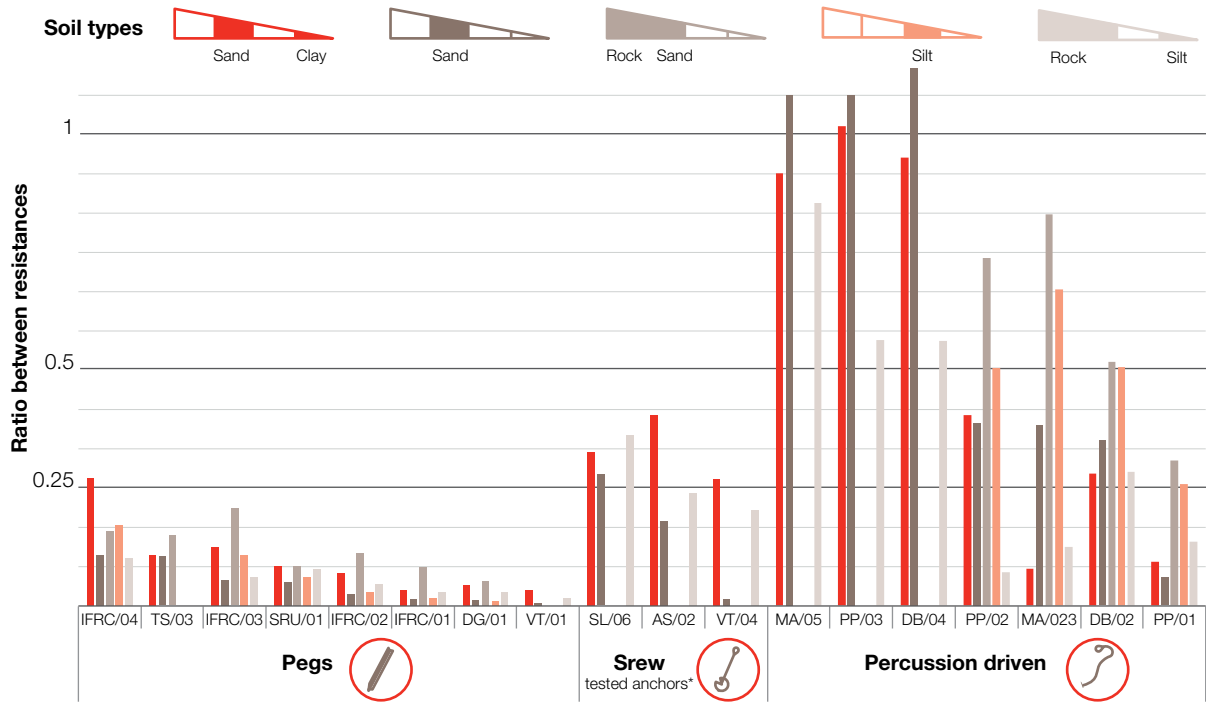

**Performance variation:**

First, one should note that the following findings are true for the maximum values only. Comparisons obtained with the maximum considering a displacement of no more than 5cm (+/-1) (see part II.C.2) do not confirm these tendencies.

**Comparison of peg anchor performances (using overall maximum values)**

\* Technical specifications in part III.D.

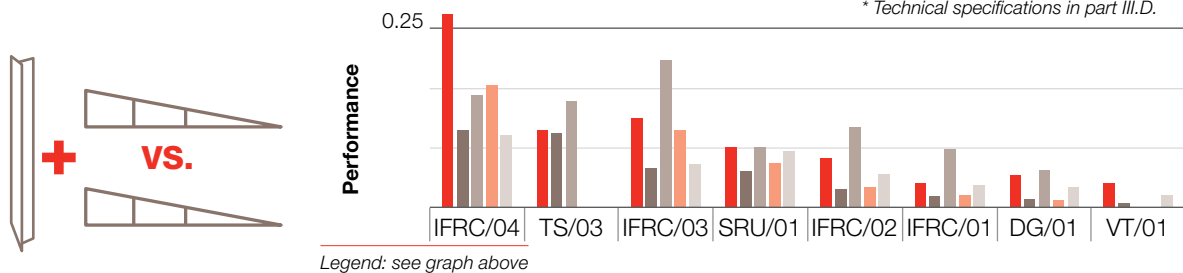

Legend: see graph above

For all pegs tested in several soils, 'clay sand' (dark red) and 'Rock Sand' (clear grey) soil work best. The only exception is the IFRC/04 anchor, and only to a small extent.

**Comparison of screw anchor performances (using overall maximum values)**

\* Technical specifications in part III.D.

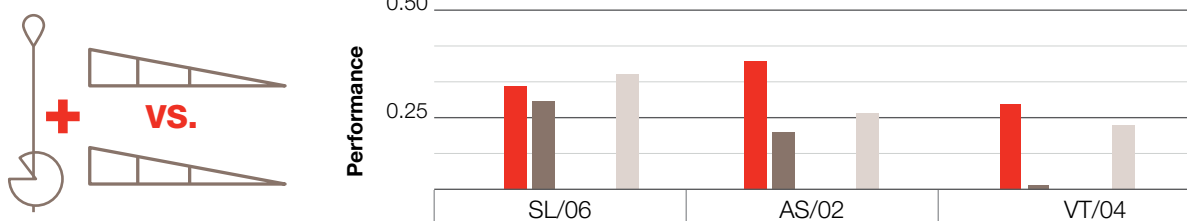

Legend: see graph above

For screw anchors, better results are always obtained for 'clay rocky sand' and 'rocky sand' than for 'sand' soil:

**Comparison of percussion driven anchor performances (using overall maximum values)**

\* Technical specifications in part III.D.

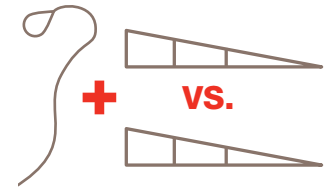
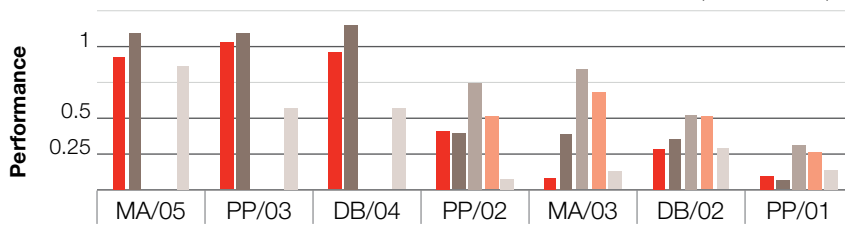

Legend: see graph above

For percussion-driven anchors, 'silt' and 'rocky sand' work best for all anchors compatible with those soils.



- The best test performances are reached by percussion driven anchors, followed by screw ones and pegs.
- Pegs were found compatible with all tested soils and show best results in 'clay sand' and 'rock sand'.
- All tested screw anchors and some big percussion driven anchors cannot be installed with human force in 'silt' and 'rocky sand' soils.
- All tested screw anchors loose resistance in sand soils.
- Tested percussion driven anchors which can be implemented with human force in 'Silt' and 'Rocky sand' show best performances in this type of soil.



**II.D.3 Practical concerns (qualitative)**

**Ease of use:**

Pegs and screw anchors are relatively easy to set up. The only drawback which applies, especially for pegs is the hazard risk once installed (for instance with children playing). Therefore, sharp ends should be removed in pegs design.

For percussion-driven anchors, the situation is clearly different: the arming process is a fundamental step which needs special skills. As it takes place invisibly, skilled experience is needed to correctly estimate whether the correct position is reached. Tensioning an unarmed anchor can have serious consequences: the anchor might lose resistance and guy ropes their tension.



**Removability, reusability:**

For pegs and screw anchors, removal is rather easy. For the first one, pulling on the axis is generally sufficient as resistance is weaker in that setting (see drawing). For the latter one, repeating the set-up instructions in the opposite order is sufficient. If the anchor is not damaged it can thus be reused for future endeavors.

For percussion-driven anchors, removal is only possible using a shovel and only if the soil allows burying. In any case, it is very time-intensive and percussion-driven anchors should be perceived as single-use. Therefore, a wrong placed percussion-driven anchor becomes a spilled anchor!

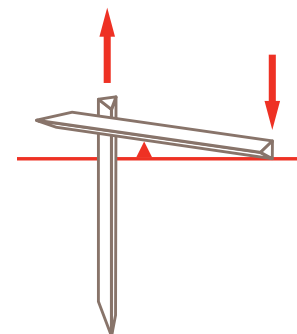

Please note that percussion-driven anchors with a second rope for disarming and removal exist. However, these ones are not recommended for use in the humanitarian as inverting the ropes can have dramatic consequences (disarming).

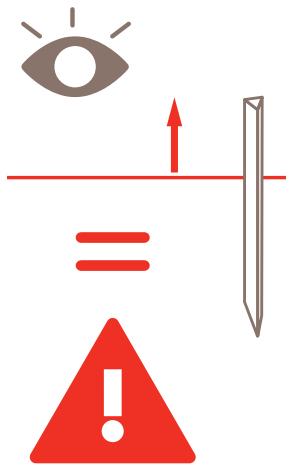

**Warning indicators:**

In the case of screw and peg anchors, upward movements have a clear and strong visual impact, even if the displacement is only of a few centimeters.! Attention: strengthening measures must be taken urgently if anchors slide out! This is very important as the rope pulls at a distance from the surface, which weakens the anchor even more (see part I.D.1.). If it is decided to double the number of pegs, an advantage is that the original ones can be kept.

For percussion-driven anchors, the indicator is much subtler as only the distance between the eye-loop and the soil can serve as such. To observe it, regular measuring and recording is necessary. A tendon reaching out of the soil needs to be considered as a serious, alarming indicator.



- While percussion-driven are the most complicated to install. Especially the arming process which takes place invisibly requires trained people.
- Percussion driven-anchors are generally of single use as removal is very time-intensive if not impossible (need to dig). Therefore, an implemented anchor cannot be corrected (i.e. moved).
- Pegs and screw anchors are easier to set up and to reuse. Also, displacements which should warn people are easier to perceive.
- Hazard risk for beneficiaries (i.e. playing children) should be minimized by avoiding sharp ends.



## II.E Further analysis

### II.E.1 Don't trust the price tag!



The ratio between price and performance is not stable. Two anchors of the same type and with the same price can show significant differences in terms of performance. NB: the price is either the cheapest commercially available one (in November 2016) on the market or an indicative one in the case of non-commercial (humanitarian) products

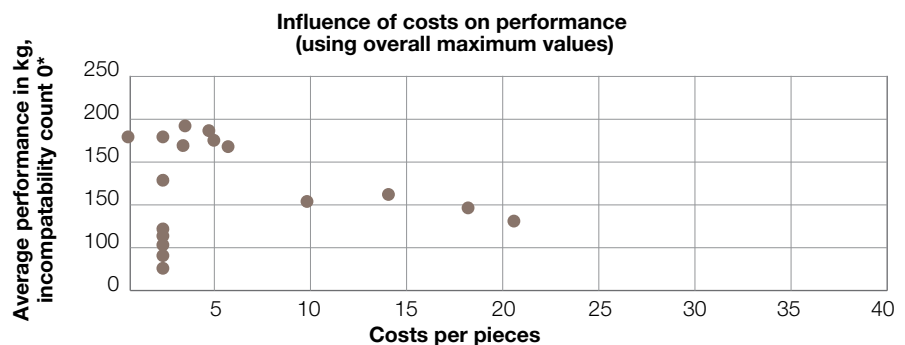

\*Note: average was calculated as follows:  $\frac{\text{results displacement} < 5\text{cm soil } a+b+c+d+e}{5}$

To stress versatility, incompatibility results were replaced by 0, the formula for incompatibility in soil b, c and d thus being:  $\frac{\text{results } a+0+0+0+e}{5}$

A graphical analysis of the average performance in function of the unit price shows that this ratio varies considerably: an anchor reaching approximately 50 kg on average can be bought for less than 5\$ or for as much as 40\$.

### II.E.2 Depth increases performance, independently of the type

In opposition to the unit price, a clear link does exist between the average performance and the depth of the 18 tested anchors. The correlation between these two data sets is 96% and thus quite high.

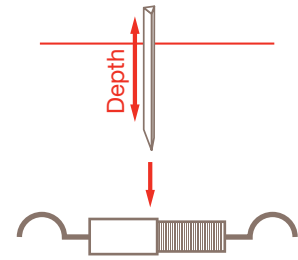
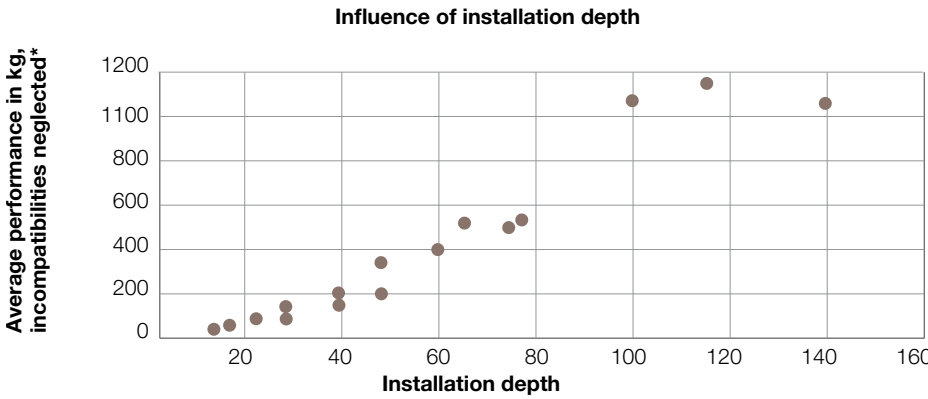

\*Note: average was calculated as follows:  $\frac{\text{overall maximum results soil a+b+c+d+e}}{5}$

To focus on the potential of the anchor, incompatibility results were neglected, the formula for incompatibility in soil b, c and d thus being:  $\frac{\text{results a+e}}{2}$

A graphical analysis of the average performance in function of the depth shows a nearly linear repartition which is confirmed by a correlation of .96.

### II.E.3 X-crossings: a limited improvement

The resistance of three anchors, one being the peg itself and the other two creating additional resistance, is 10% higher than the one of a single peg.

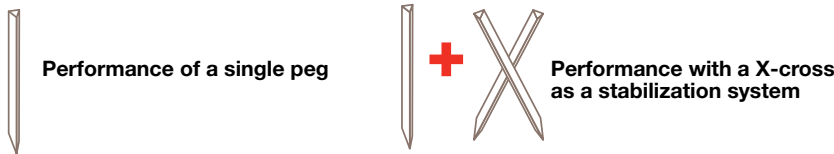

Measured performances

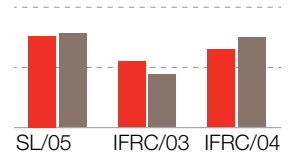

\* Technical spec. in part III.D.

### II.E.4 Combine pegs!

In order to increase forces, anchors can be combined by connecting several anchors to the same guy rope. As, the same soil might be compressed twice, the force transferred per peg decreases.

Multiplication of force resistance as published by IFAI  
Please note that this data is provided for nail shaped pegs

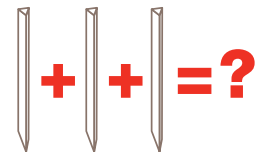
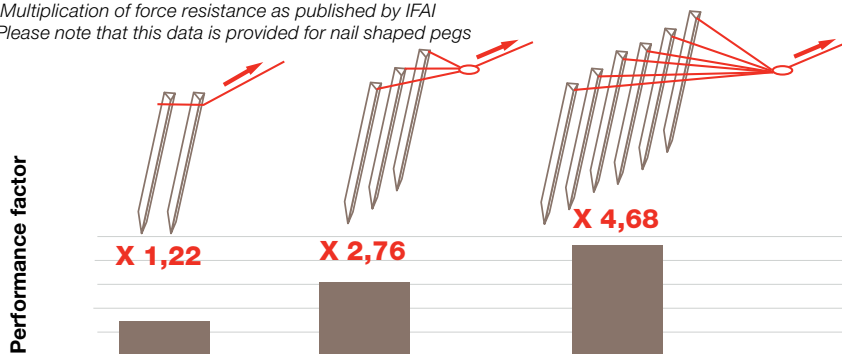

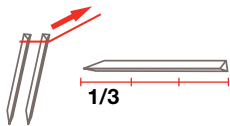

For the situation with two pegs in the axis, shown on the left IFAI recommends a distance of 1/3 of the anchor length between the anchors.

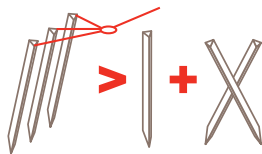

Basing on the literature used in this part and the test results of the previous one (II.E.3.), pegs perform better when combined as active pegs which are all attached to the guy rope. With three pegs a performance increase of 176% can be reached. Observed test results of the x-crossings show an increase of only 10%.

### II.E.5 Combine percussion-driven anchors!

A similar test was conducted with 3 different types of percussion-driven anchors. For each set a test was made with one and the other with four anchors. The resistance does clearly increase but the ratio is unstable: it can be 10 times bigger, triple or only double.

Measured performances

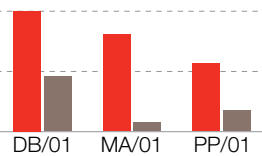

\* Technical spec. in part III.D.



4 pegs combined in one anchoring point



One single peg



- The price of an anchor is not a reliable indicator. Performance is clearly influenced by other factors.
- Depth is a reliable indicator: independently of the type of anchor, performance will increase with increasing depth
- Basing on test results and literature, pegs perform better if combined as active ones rather than as x-crossing.
- Combining percussion-driven anchors is also an option to increase resistance.



## II.F Conclusions

This study indicates a few phenomenon of which some were already discussed in the first part:

- The external context (weather conditions, soil conditions, type of soil) has a strong influence on the soil and thus the performances of the anchors.
- The unit price of anchors is not a reliable indicator
- Combining increases the overall performance but might create a loss in the performance per unit. This is true for both pegs and percussion-driven anchors.

This study gives an insight into the potential of several types of steel anchors:

- Peg anchors have a limited performance but can easily be implemented in all types of soil, even by unexperienced people.
- Screw anchors have higher performances and are easy to implement in some types of the soil. However, human force is insufficient to implement them in some soils.
- Percussion driven anchors show interesting force resistances but require technically skilled people to be implemented safely. Especially the invisible arming process is challenging. Also, the biggest models can be incompatible with hard soils.

Choosing an anchors is a matter of balance between performance and complexity. Peg anchors appear to be a good option due to their ease of use and versatility. Their main limitation is the performance. On the other hand,

percussion-driven show performances that can hardly be reached by screw or peg anchors. However, their technical complexity and versatility, requiring more care and raising installation costs is a major drawback. Their application should be considered carefully and for compatible soil, staff and material only. These drawbacks make them mainly interesting for building with a big value that can justify the extra complexity and big force requirements.



- When choosing an anchor, one should not only bear the soil and weather conditions but also the installation procedure in mind. Who is going to install the anchors in the soil? If the answer to this question is unsure, choose an anchor which is easy to install. Otherwise, the risk of wrong installation increases.
- Furthermore, it was noticed that one can increase the performance of anchors by either combining them or using longer models. However, simply buying a more expensive anchor is not recommended.



## II.G Alternatives

**Conclusion table:** Comparison of the different anchor options considering technical and practical aspects

Technical aspects	Performance	+	++	+++	+++
	Versatility	★★★★★	★★★★☆	★★★★☆	★★★★★
	Piece costs	\$	\$\$	\$\$\$	\$
	Weight				
	Combinations	★★★★★	★★★★☆	★★★★☆	★★★★★
Practical aspects	Extra materiel				
	Instructions	1	1	2	1
	Time				
	Monitoring	3	3	4	3
		Performance Complexity	Performance Complexity	Performance Complexity	Performance Complexity

1 Instruction manual  
 2 Skilled personal  
 3 Visual inspection  
 4 Visual inspection + measure + document





Local alternatives nearly always exist and are worth discussing here. In fact, they are often good solutions, saving logistics and providing employment to local populations. To name just a few, here are some options for ballast anchors:

- Wood as buried
- Big rocks or refilled oil barrels
- Old or functional cars/trucks, eventually filled with mass
- Car tires/wheels filled with sand
- Textile bags/packages filled with local soil

An aspect which has been identified earlier is the limited capacity of anchors and the need to reinforce them temporarily if extreme weather conditions apply. Some alternatives such as using functional cars as ballast are suited for such situations.

To illustrate this, four alternative approaches will be discussed here. These four approach do not only show options but also different means to identify such:

### Alternative approach 1: appropriate tools of other uses.



This first approach was tested during the test sets. It is a screw tool (hand auger) used by gardeners to make holes. This one was inserted into the soil and reached a considerable maximum value of 512 kg for a displacement of 5cm(+/-1) and an absolute maximum resistance of 1500kg.

This shows that product being designed for a different purpose can very effectively be used as anchors, sometimes even showing better results than specifically designed anchors themselves.

### Alternative approach 2: local practices - vernacular architecture



Nomad populations exist or existed in many regions of the world. As their buildings are lightweight and temporary, they have been confronted to similar challenges. In fact, some groups use interesting alternatives. Bedouins for instance use local bush vegetation which they dig into the sand before attaching the guy rope.

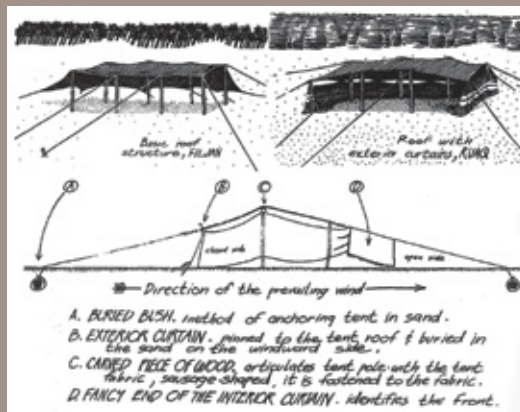

(left: Couchaux, Denis, *Habitats Nomades. Collection Anarchitecture, 2nd edition. Paris: éditions Alternatives, 2011. p.66*)

This shows that knowledge of local and nomad populations can be of major interest. Means to identify those practices include not only members of the practicing groups but also local populations, publications, archives, etc.

### Alternative approach 3: use local resources - textile earth bags

Hypothetical situation: a specialist calculated that the anchoring point needs to resist to a force of X by a diagonal guy rope, under the exact conditions and with the exact shelter type.

**Attention:** a diagonal force of 200 kg cannot be bore by a ballast of 200 kg. Ballast can only be equal to the force if the latter is entirely vertical.

According to another calculation, the ballast needs to weight X kg in order to provide sufficient friction. For an earth bag buried into the soil, only Y kg (assumption for the example: 275kg) are needed as the contact surface with the soil (in red) is bigger.

Material needed: a shovel and extra textile bag packaging. As the density of earth<sup>1</sup> is at least 1100 kg/m<sup>3</sup>, 10 bags of .25 m<sup>3</sup> should be used (.25\*10\*1200=275 kg). This is equivalent to 20 additional packages of .125 m<sup>3</sup> (two per anchor) each (21 in total - the original outer one might be damaged due to its protective function). The total weight of this alternative is approximately 4.3 kg, divided into:

- 20 polycotton packages of a volume of .13 m<sup>3</sup> and a weight of 180 g (1 m<sup>2</sup> of 180g/m<sup>2</sup>). 20\*.18 = 3.6 kg
- A shovel weights approximately 1.5 kg.

Replacing the anchors by this option would thus mean a weight economy of 3.0 kg (5.45% of the package weight).

**Attention:** before using this method, further studies concerning its influence on the soil and the environment is needed (influence on vegetation, humidity and textiles). Also, the **durability** of several types of textile should be explored to choose the most appropriate one.



- Many other alternative approaches exist. The ones discussed in this part are only examples to illustrate possible strategies
- Sometimes, alternatives require extensive research before becoming applicable. Examples are the durability of buried wood and textiles. The lifetime of anchors should in fact exceed the one of the building itself.
- Inspiration can often be gathered from related fields. For instance, sheet piling within earth engineering can give ideas for combinable anchors.



<sup>1</sup> Harto, Christopher, Soil Density. [online] Lemont (U.S.A.): Argonne National Laboratory. [accessed 02 January 2017] Available from: <http://web.ead.anl.gov/resrad/datacoll/soildens.htm>

III.

# Recommendations for application

## III.A Triple AAA: Alternatives, Accessible, Aware

One of the major findings of this study is that the usage of anchors is not a linear process which starts with the initiative to build and stops after the construction. Anchors are an essential part of any shelter's structure need to be monitored and, if necessary, corrected after installation. This procedure is in fact cyclic (see below):

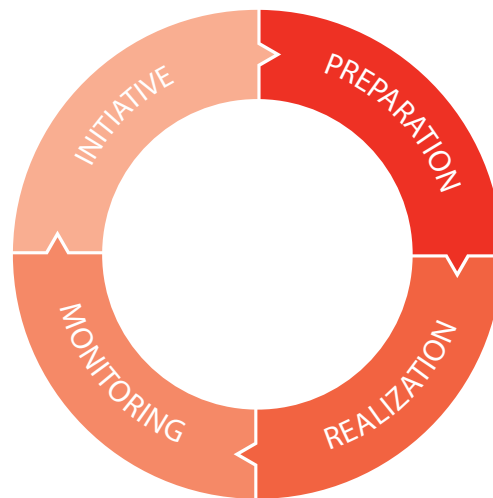

During all these steps, the three As which have been discussed all along this publication should be considered:



**Aware:** Anchors are a serious topic and small things might in fact be huge differences. Always make sure that the full potential of anchors is used! Also, all anchors have limitations and will fail under too extreme conditions. Keep eyes open for changing conditions! If any doubts appear, don't look away and clarify them as fast as possible.

**Accessible:** Both people installing and using the anchors (sometimes the same) must be considered in the decisions. Some anchors can only be used by trained staff while others require only clear instructions on paper.

Also, it is necessary to imply beneficiaries in monitoring the anchors once installed. Indicators such as anchor displacements should not be ignored, neither by the providers nor the beneficiaries.

**Alternative-open:** Why search the solution far away if it might just be in front of you? Often, local alternatives – for instance reusing products exist and can be fitted for this purpose. On top of that, such proceedings reduce transportation and sustain local economy.

Basing on these findings, a set of recommended check-lists has been formulated and can be found in the next part.

## III.B Basic recommendations for safe usage



### 1. Choosing an anchor

- If the exact location is known: Identify the soil type and potential variations. Are there any previous catastrophes which might have affected the soil conditions? (I.D.3)
- Consider local alternatives. Identify goods which can be bought locally. (II.F.)
- Is the group of persons who will install the anchors known? Is it rather small (i.e. staff) or big (i.e. beneficiaries)? Can any trainings be provided? (II.C.3.)
- Identify options and discuss them with local population: would they use it? Which instructions are necessary for safe use?
- If possible, test one or two options on a tent for a few days. The effort can be reduced by using already installed tents, for instance in the base camp.

### 2. Distributing anchors

- Make an instruction plan: will trainings be provided? Will instruction drawings be distributed?
- Is the group of people who will install the anchors the expected one? If not, adapt the instruction plan accordingly.
- Set up a short-term monitoring plan and, if necessary, integrate it in the trainings: Who will keep an eye on the anchors? How often? To who should weakness indicators be reported? By which means?
- Realize the trainings/Print the instructions.

### 3. Using anchors

- Check the installation of the anchors. Have all the anchors been installed correctly? Are any weaknesses observed? (I.D.1. & II.C.3.)
- Realize the monitoring plan and collect information. Make a long-term monitoring plan. While the frequency might decrease, special attention is required when context changes (soil humidity, strong winds).

### A)...in the case of expecting temporary weaknesses

- Contact a professional and get reliable information about the increase in forces. How much tension in kg could apply to the anchor? Is strengthening the anchors needed?
- Make a fast plan: how much time is left. What are the realistic ones? Can durable options that will avoid the same situation in the future be implemented?
- If no options to reinforce the anchors exist, dismount the shelters (if possible)! A damaged shelter is worse than a dismounted one!
- Once the extreme conditions are over, the strengthening measures might be removed or the shelters rebuilt (anchors can be reused)

**Go back to : 3) using anchors**

**B)...in the case of observing weaknesses**

- Document and reinstall the anchors correctly, making a new hole (I.D.1.)
- Make a short-term plan first and then a long term one. Are durable improvements directly implementable? Or are temporary ones necessary in a first instance?
- Consider both long-term strengthening (for instance doubling the anchors) and replacing them. (II.D. and II.F.)

**Go back to : 1) choosing an anchor**

## 5. Alternatives: look in front of you!

In nearly all place of the world, **alternative products which can be transformed into anchors exist**. They offer a serious alternative, being directly available, cheaper and more sustainable than anchors shipped globally. Some options are:

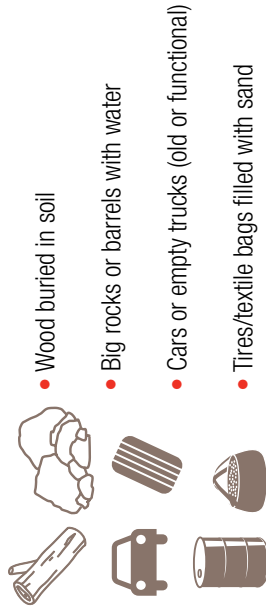

These alternatives can also be useful to address **temporary situations**, to strengthen anchors for a short period of time (e.g. during storms).

**If temporary strengthening is required but unfeasible, dismount the buildings if possible!**

## 6. Ballast: fill bags with earth and bury them



Bags filled with earth can be used as a ballast (1 m<sup>3</sup> of soil weights at least 1100 kg).

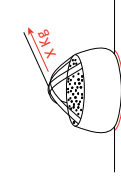

A **diagonal force of X kg** requires a ballast heavier than X kg to create sufficient resistance by friction.

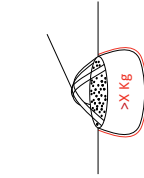

In order to increase friction, ballast anchors should be **buried** into the soil. This can be done by digging a hole while filling the bag.

**Good anchoring practice** fulfills three As:

### Aware:

Anchors are a serious topic and **small things might result in huge differences**. Always make sure you that the **full potential of anchors** is used.

As all anchors have limitations, keep eyes open for **changing conditions** and act if necessary.

### Accessible:

Both **people installing and using the anchors should be considered beforehand**. While some anchors can only be used by trained staff, others only require clear paper instructions. Furthermore, beneficiaries can also participate in **monitoring**.



### Alternative-open:

**Before considering solutions far away, look at those in front of you**. Often, used products can be transformed and offer faster, cheaper and more sustainable anchor.

## Usage of soil anchors for humanitarian shelter

A field pocket guide, part of the anchoring manual



International Federation of Red Cross and Red Crescent Societies

**Shelter Research Unit**  
Innovating shelter

## Always keep an eye on the anchors and watch out for risks!

Anchors ask for a circular process composed by four steps: Initiation, Preparation, Realization, Monitoring. Even once anchors are installed and buildings set-up, **monitoring is necessary to identify and avoid predicabile failures early enough**.

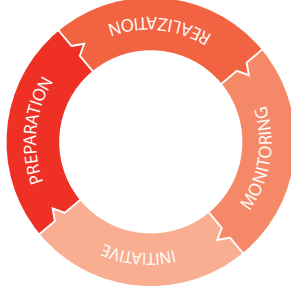

### IFRC- SRU

Headquarters  
Cité Henri Dunant 10, L-8095  
Bertrange, Luxembourg  
Tel.: +352 27 55 – 8902  
ifrc-sru@croix-rouge.lu

*The Manual has been drafted and published by the IFRC-SRU. Any commercial usage of this document or parts of it is strictly prohibited. It might be reproduced and spread, partially or entirely, as long as the original author is mentioned.  
The IFRC – Shelter Research Unit is in no way responsible for any errors or omissions that may arise from the use of the Manual. Users assume all risks and responsibilities.*



# 1. Foundations: vital to any building!



Above the ground

Under the ground

Anchors are a form of foundations and therefore **vital and integrated to the building structure**. In fact, anchor failure can have **dramatic consequences!**

## Forces pulling on the anchor depend on...:

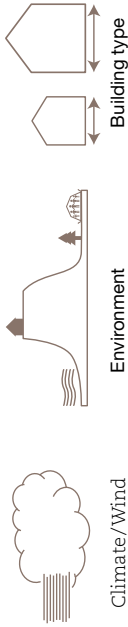

**Wind Speed ≠ Wind Pressure**

## Environment modifies soil, soil modifies anchors – every single day!

Each soil is **unique** not only due to its composition but also due to the **permanently changing context**:



Among **many environmental parameters**, humidity and freezing modify the soil and anchor performances.



**Imply local inhabitants** to identify natural and human activity which affect soil conditions and thus anchor performances. They know the place better than anyone else!

## Good to know (for all anchors)

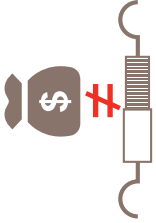

### Don't listen to the price tag:

A more expensive anchors are not necessarily performing better!

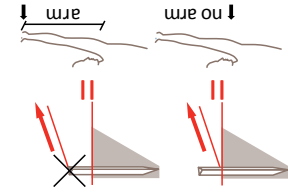

### Attach the ropes at soil level

Putting a rope at the **lower rather than upper end** of the anchor is like pulling on the bottom rather than the top of an arm.

### Fix loose anchors immediately

Loose anchors are considerably weaker and **should immediately be reinstalled making a new hole**, even if a lasting solution is being found.

## 2. Pegs: boost the performance by putting them in the right position

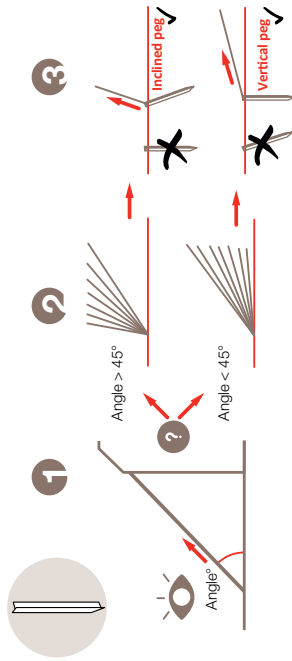

Never incline the peg, unless the **angle between guy rope and ground** is bigger than 45°.

V- and T-pegs should always be implemented **pointing to the tent**.

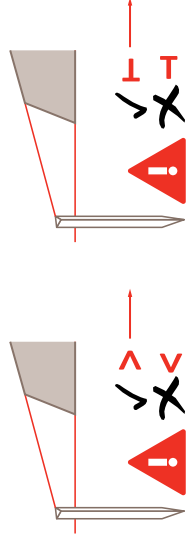

## Need to multiply the resistance? Multiply the pegs!

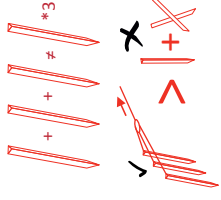

When using several pegs, performance loss always occurs, but can be limited. Pegs are more efficient if combined as active pegs and not as x-crossings.

## 3. Screw anchors: avoid them in hard soils

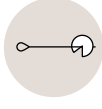

Screw anchors show better performances than pegs but **cannot be implemented with human force in hard or compact soils**. They can best be used to resist vertical forces.

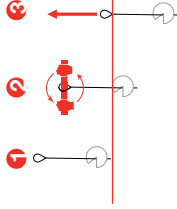

A tool is required to turn the screw anchor into the soil. This might be another screw anchor or a bar made of steel or wood.

## 4. Mechanical anchors: only use them with specifically trained staff!





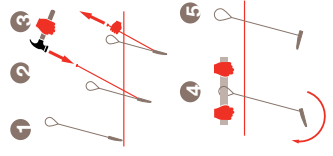











A hammer, a steel rod and **technically trained staff are required or compact soils**. They can best be used to resist vertical forces.



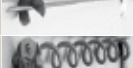

Percussion driven anchors show strong performances but **require trained technical staff to be installed**. This creates additional costs and makes them mainly interesting for expensive and temporary structures. Also, **big models cannot be implemented with human force in hard and compact soil**.



## III.D Tested anchor specifications

Code	Supplier	Picture	Model	Family	Weight (g)	Dimension (mm)	Installation Depth (cm)	Unit price on USD (Nov. 2016) US\$
DG/01	Delta Ground Anchors		Plastic stake	Peg	48	155	15	1.86
IFRC/01	Humanitarian (IFRC catalogue <sup>1</sup> )		Family tent stake 220 mm	Peg	143	220	18	0.39
IFRC/02			Family tent stake 280 mm	Peg	282	280	24	0.6
IFRC/03			Family tent stake 350 mm	Peg	400	350	30	1.06
IFRC/04			27,5 m <sup>2</sup> multipurpose tent stake	Peg	485	510	50	1.55
SRU/01	SRU		prototype	Peg	315	350	30	1.3
TS/03	Tougstake		Sand/Snow stake 3	Peg	198	444	40	40
VT/01	Vortex		Yard anchor	Peg	20	150	15	1.75
AS/02	Anchor system		Auger 40	Screw	1310	600	50	Not provided
SL/06	ShelterLogic		Shelterauger 30	Screw	700	762	60	5
VT/04	Vortex		Spiral Anchor 16	Screw	775	400	40	13.97
DB/02	Duckbill		68-D8D	Mechanical	92	68	75	5.72
DB/04			MR4	Mechanical	500	138	140	20.7
MA/03	Milspec Anchors		Arrowhead 3	Mechanical	238	75	78	3.1
MA/05			Arrowhead 6	Mechanical	707	150	115	18.2

Code	Supplier	Picture	Model	Family	Weight (q)	Dimension (mm)	Installation Depth (cm)	Unit price on USD (Nov. 2016) US\$
PP/01	Platipus		Platipus S2	Mechanical	50	70	50	2.96
PP/02			Platipus S4	Mechanical	180	121	67.5	4.75
PP/03			Platipus S6	Mechanical	530	171	100	9.87

As a wide-spread foundation technique, anchors are integrated in the structure and therefore of primary importance for any building using it.

While consequences can be dramatic, the invisible phenomenon's affecting anchors are very complex. In fact, an anchor is influenced by no less than two variable environments: the climatic forces and the soil conditions. Both are changing on punctual and cyclic basis which makes them hard to estimate.

This study is an innovative approach to the usability of different types of anchors in the humanitarian context. It is complemented by the results of own resistance tests conducted with 18 different anchors. Along with a critical perspective, practical concerns and an eye for alternatives, they result in clear findings.

The study ends with a summary of those, aimed at field practice (including a check-list and a handout). Finally, good anchoring practice is defined by 3A's which are present all along the study: Aware, Accessible and Alternative-open.

To download this document and for more information, please visit :

[www.ifrc-sru.org](http://www.ifrc-sru.org)



# The Fundamental Principles of the International Red Cross and Red Crescent Movement

**Humanity** The International Red Cross and Red Crescent Movement, born of a desire to bring assistance without discrimination to the wounded on the battlefield, endeavours, in its international and national capacity, to prevent and alleviate human suffering wherever it may be found. Its purpose is to protect life and health and to ensure respect for the human being. It promotes mutual understanding, friendship, cooperation and lasting peace amongst all peoples.

**Impartiality** It makes no discrimination as to nationality, race, religious beliefs, class or political opinions. It endeavours to relieve the suffering of individuals, being guided solely by their needs, and to give priority to the most urgent cases of distress.

**Neutrality** In order to enjoy the confidence of all, the Movement may not take sides in hostilities or engage at any time in controversies of a political, racial, religious or ideological nature.

**Independence** The Movement is independent. The National Societies, while auxiliaries in the humanitarian services of their governments and subject to the laws of their respective countries, must always maintain their autonomy so that they may be able at all times to act in accordance with the principles of the Movement.

**Voluntary service** It is a voluntary relief movement not prompted in any manner by desire for gain.

**Unity** There can be only one Red Cross or Red Crescent Society in any one country. It must be open to all. It must carry on its humanitarian work throughout its territory.

**Universality** The International Red Cross and Red Crescent Movement, in which all societies have equal status and share equal responsibilities and duties in helping each other, is worldwide.

**For more information on this IFRC-SRU publication,  
please contact:**

**IFRC- SRU**

Cité Henri Dunant 10, L-8095

Bertrange, Luxembourg

Tel.: +352 27 55 – 8902

[ifrc-sru@croixrouge.lu](mailto:ifrc-sru@croixrouge.lu)

<http://ifrc-sru.org/>

**[www.ifrc.org](http://www.ifrc.org)**  
**Saving lives, changing minds.**



International Federation  
of Red Cross and Red Crescent Societies

**Shelter Research Unit**  
Innovating shelter